

LM2704

Micropower Step-up DC/DC Converter with 550mA Peak Current Limit

General Description

The LM2704 is a micropower step-up DC/DC in a small 5-lead SOT-23 package. A current limited, fixed off-time control scheme conserves operating current resulting in high efficiency over a wide range of load conditions. The 21V switch allows for output voltages as high as 20V. The low 400ns off-time permits the use of tiny, low profile inductors and capacitors to minimize footprint and cost in space-conscious portable applications. The LM2704 is ideal for LCD panels requiring low current and high efficiency as well as white LED applications for cellular phone back-lighting. The LM2704 can drive up to 8 white LEDs from a single Li-Ion battery.

Features

- 550mA, 0.7 Ω , internal switch
- Uses small surface mount components
- Adjustable output voltage up to 20V
- 2.2V to 7V input range
- Input undervoltage lockout
- 0.01 μ A shutdown current
- Small 5-Lead SOT-23 package

Applications

- LCD Bias Supplies
- White LED Back-Lighting
- Handheld Devices
- Digital Cameras
- Portable Applications

Typical Application Circuit

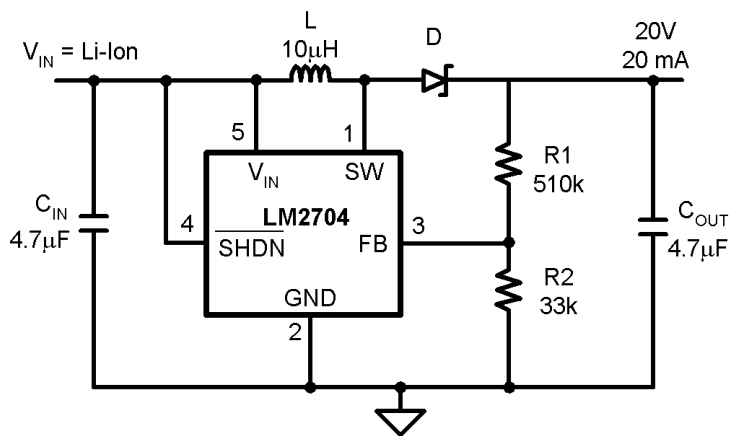

C_{IN} : Taiyo Yuden Ceramic
 C_{OUT} : Taiyo Yuden Ceramic
 L: Coilcraft DO1608C-103
 D: Motorola MBRM130LT3

20031501

FIGURE 1. Typical 20V Application

Connection Diagram

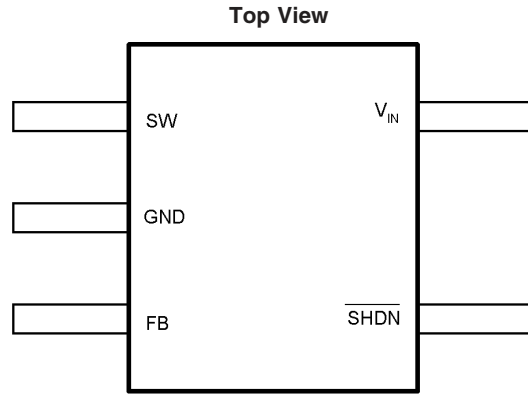

20031502

SOT23-5

 $T_{Jmax} = 125^{\circ}\text{C}$, $\theta_{JA} = 220^{\circ}\text{C/W}$ (Note 2)

Ordering Information

Order Number	Package Type	NSC Package Drawing	Top Mark	Supplied As
LM2704MF-ADJ	SOT23-5	MA05B	S28B	1000 Units, Tape and Reel
LM2704MFX-ADJ	SOT23-5	MA05B	S28B	3000 Units, Tape and Reel

Pin Description/Functions

Pin	Name	Function
1	SW	Power Switch input.
2	GND	Ground.
3	FB	Output voltage feedback input.
4	SHDN	Shutdown control input, active low.
5	V _{IN}	Analog and Power input.

SW(Pin 1): Switch Pin. This is the drain of the internal NMOS power switch. Minimize the metal trace area connected to this pin to minimize EMI.

GND(Pin 2): Ground Pin. Tie directly to ground plane.

FB(Pin 3): Feedback Pin. Set the output voltage by selecting values for R1 and R2 using:

$$R1 = R2 \left(\frac{V_{OUT}}{1.237V} - 1 \right)$$

Connect the ground of the feedback network to an AGND plane which should be tied directly to the GND pin.

SHDN(Pin 4): Shutdown Pin. The shutdown pin is an active low control. Tie this pin above 1.1V to enable the device. Tie this pin below 0.3V to turn off the device.

V_{IN}(Pin 5): Input Supply Pin. Bypass this pin with a capacitor as close to the device as possible.

Absolute Maximum Ratings (Note 1)

If Military/Aerospace specified devices are required, please contact the National Semiconductor Sales Office/Distributors for availability and specifications.

V_{IN}	7.5V
SW Voltage	21V
FB Voltage	2V
\overline{SHDN} Voltage	7.5V
Maximum Junction Temp. T_J (Note 2)	150°C
Lead Temperature (Soldering 10 sec.)	300°C
Vapor Phase (60 sec.)	215°C

Infrared (15 sec.)	220°C
ESD Ratings (Note 3)	
Human Body Model	2kV
Machine Model (Note 4)	200V

Operating Conditions

Junction Temperature (Note 5)	-40°C to +125°C
Supply Voltage	2.2V to 7V
SW Voltage Max.	20.5V

Electrical Characteristics (Note 5)

Specifications in standard type face are for $T_J = 25^\circ\text{C}$ and those in **boldface type** apply over the full **Operating Temperature Range** ($T_J = -40^\circ\text{C}$ to $+125^\circ\text{C}$). Unless otherwise specified. $V_{IN} = 2.2\text{V}$.

Symbol	Parameter	Conditions	Min (Note 5)	Typ (Note 6)	Max (Note 5)	Units
I_Q	Device Disabled	FB = 1.3V		40	70	μA
	Device Enabled	FB = 1.2V		235	300	
	Shutdown	$\overline{SHDN} = 0\text{V}$		0.01	2.5	
V_{FB}	Feedback Trip Point		1.189	1.237	1.269	V
I_{CL}	Switch Current Limit		490 420	550	610 620	mA
I_B	FB Pin Bias Current	FB = 1.23V (Note 7)		30	120	nA
V_{IN}	Input Voltage Range		2.2		7.0	V
R_{DSON}	Switch R_{DSON}			0.7	1.6	Ω
T_{OFF}	Switch Off Time			400		ns
I_{SD}	\overline{SHDN} Pin Current	$\overline{SHDN} = V_{IN}, T_J = 25^\circ\text{C}$		0	80	nA
		$\overline{SHDN} = V_{IN}, T_J = 125^\circ\text{C}$		15		
		$\overline{SHDN} = \text{GND}$		0		
I_L	Switch Leakage Current	$V_{SW} = 20\text{V}$		0.05	5	μA
UVP	Input Undervoltage Lockout	ON/OFF Threshold		1.8		V
V_{FB} Hysteresis	Feedback Hysteresis			8		mV
\overline{SHDN} Threshold	\overline{SHDN} low			0.7	0.3	V
	\overline{SHDN} High		1.1	0.7		
θ_{JA}	Thermal Resistance			220		$^\circ\text{C}/\text{W}$

Note 1: Absolute maximum ratings are limits beyond which damage to the device may occur. Operating Ratings are conditions for which the device is intended to be functional, but device parameter specifications may not be guaranteed. For guaranteed specifications and test conditions, see the Electrical Characteristics.

Note 2: The maximum allowable power dissipation is a function of the maximum junction temperature, $T_J(\text{MAX})$, the junction-to-ambient thermal resistance, θ_{JA} , and the ambient temperature, T_A . See the Electrical Characteristics table for the thermal resistance. The maximum allowable power dissipation at any ambient temperature is calculated using: $P_D(\text{MAX}) = (T_J(\text{MAX}) - T_A)/\theta_{JA}$. Exceeding the maximum allowable power dissipation will cause excessive die temperature.

Note 3: The human body model is a 100 pF capacitor discharged through a 1.5 k Ω resistor into each pin. The machine model is a 200 pF capacitor discharged directly into each pin.

Note 4: ESD susceptibility using the machine model is 150V for SW pin.

Note 5: All limits guaranteed at room temperature (standard typeface) and at temperature extremes (bold typeface). All room temperature limits are 100% production tested or guaranteed through statistical analysis. All limits at temperature extremes are guaranteed via correlation using standard Statistical Quality Control (SQC) methods. All limits are used to calculate Average Outgoing Quality Level (AOQL).

Note 6: Typical numbers are at 25°C and represent the most likely norm.

Note 7: Feedback current flows into the pin.

Typical Performance Characteristics

Enable Current vs V_{IN}
(Part Switching)

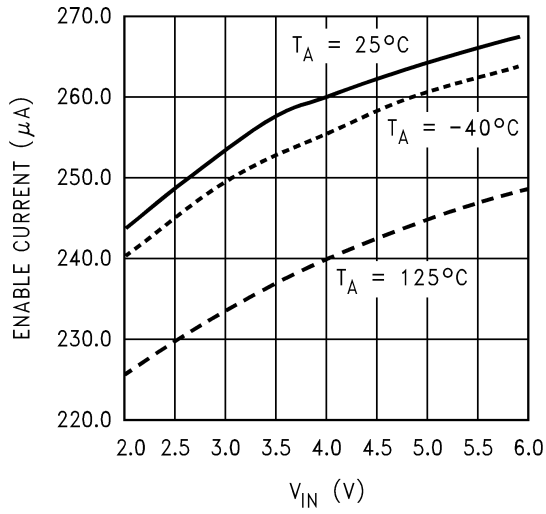

20031505

Disable Current vs V_{IN}
(Part Not Switching)

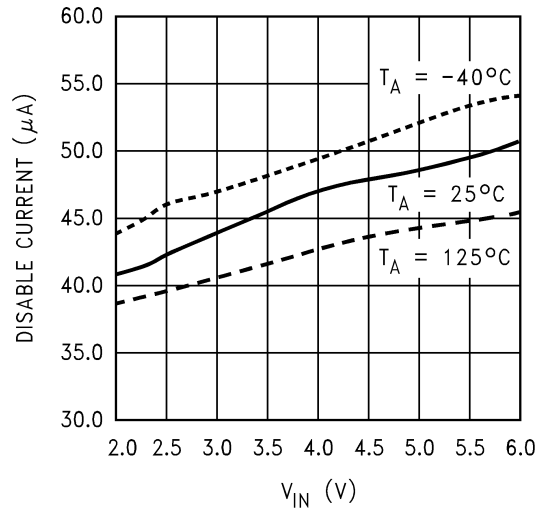

20031506

Efficiency vs Load Current

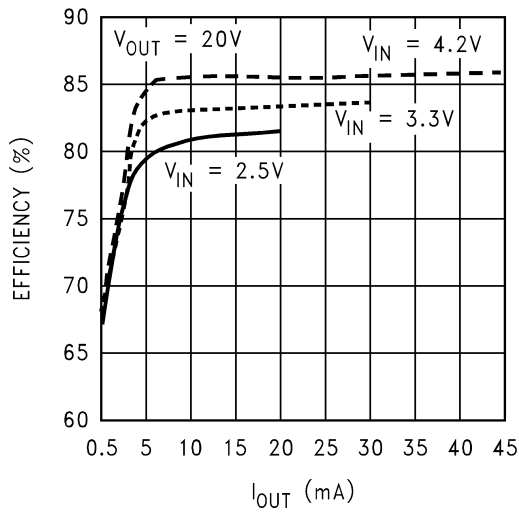

20031510

Efficiency vs Load Current

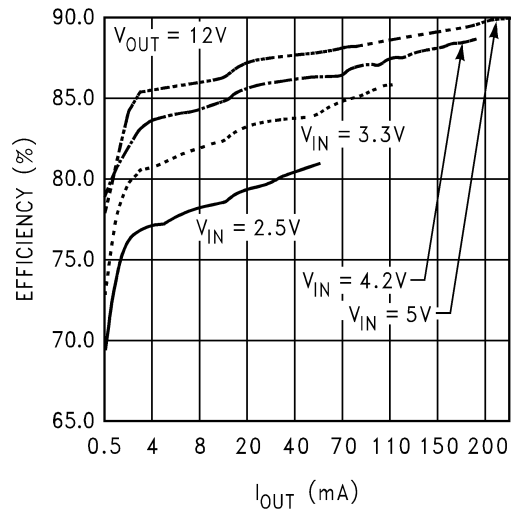

20031511

Typical Performance Characteristics (Continued)

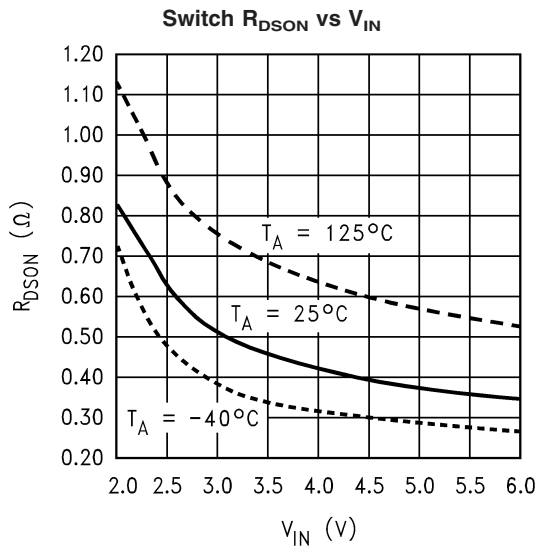
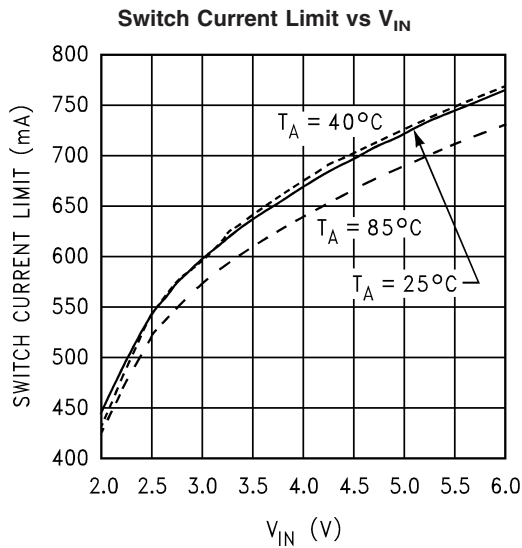
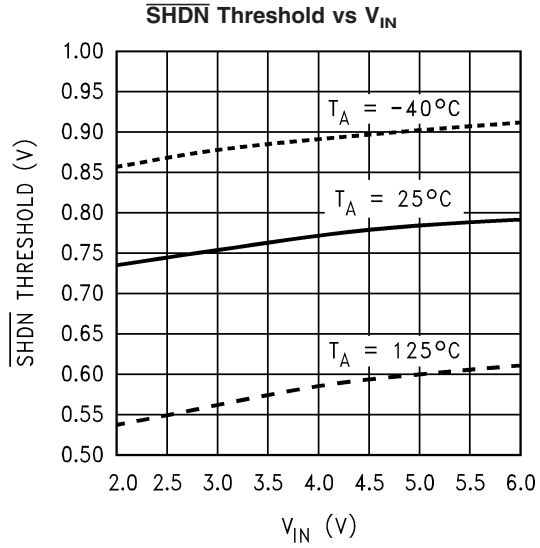
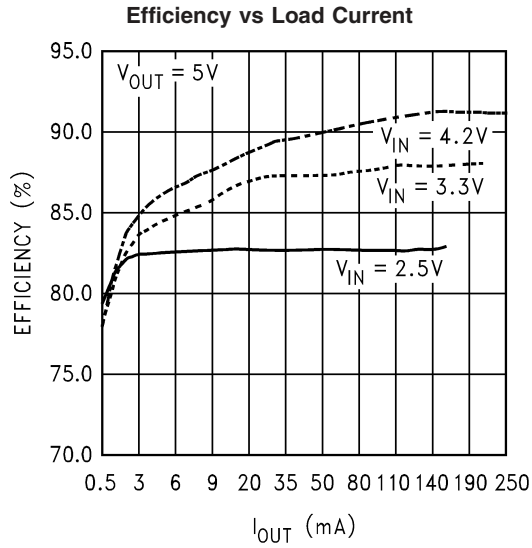

Typical Performance Characteristics (Continued)

FB Trip Point and FB Pin Current vs Temperature

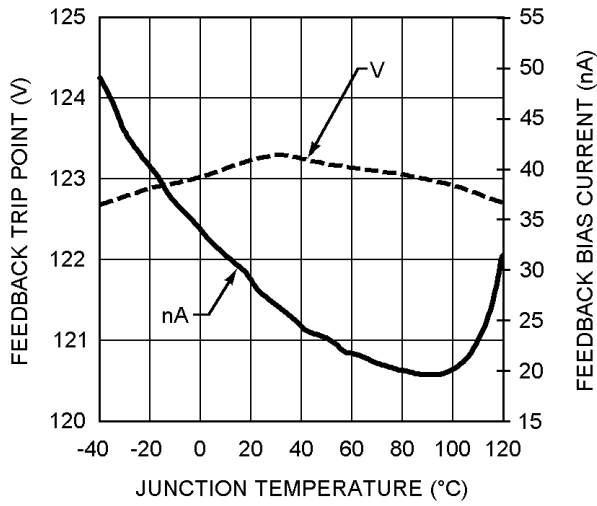

20031538

Output Voltage vs Load Current

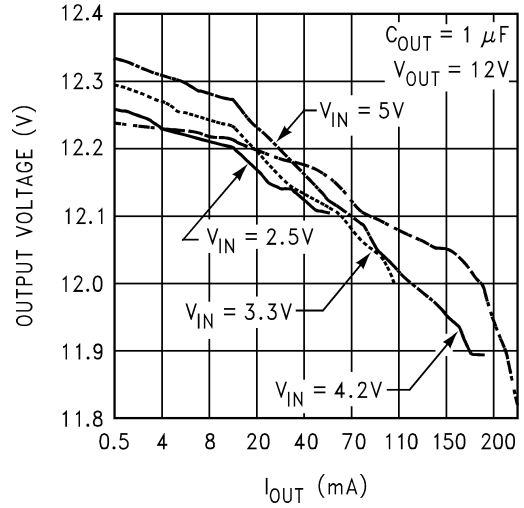

20031537

Step Response

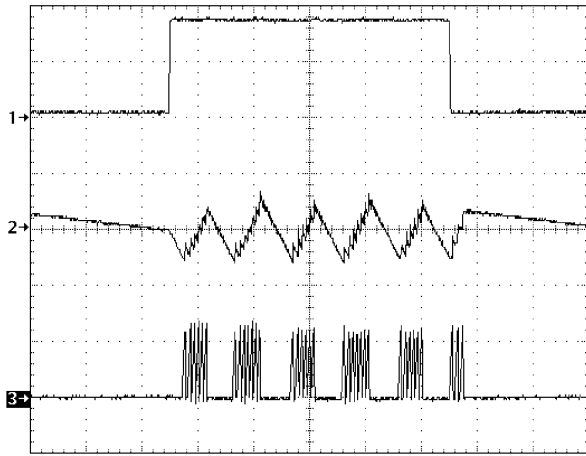

20031516

$V_{OUT} = 20V, V_{IN} = 3.0V$

- 1) Load, 1mA to 17mA to 1mA, DC
- 2) V_{OUT} , 200mV/div, AC
- 3) I_L , 500mA/div, DC
- T = 40 μ s/div

Start-Up/Shutdown

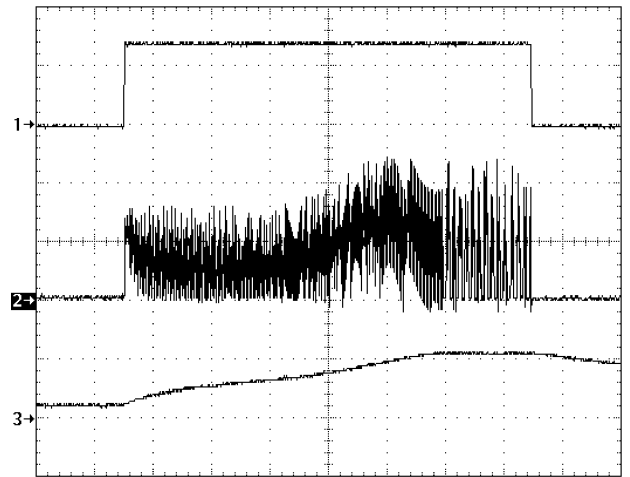

20031517

$V_{OUT} = 20V, V_{IN} = 2.5V$

- 1) SHDN, 1V/div, DC
- 2) I_L , 250mA/div, DC
- 3) V_{OUT} , 20V/div, DC
- T = 400 μ s/div
- $R_L = 1.3k\Omega$

Operation

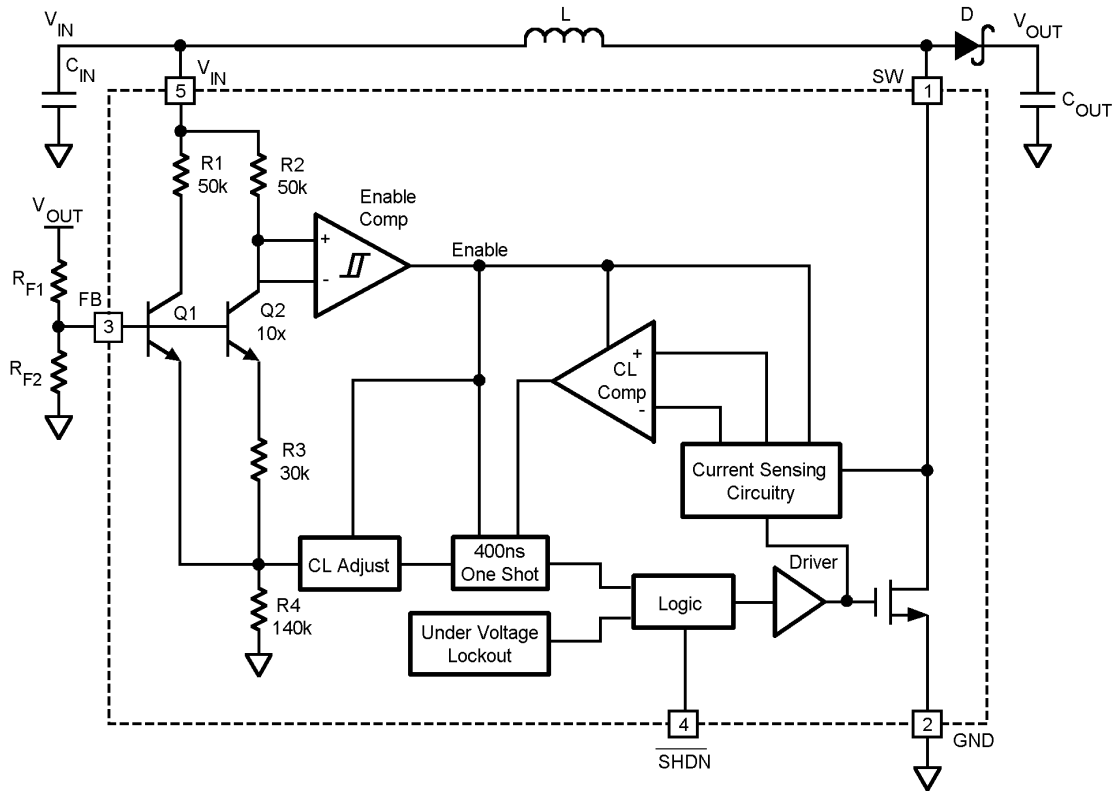

20031504

FIGURE 2. LM2704 Block Diagram

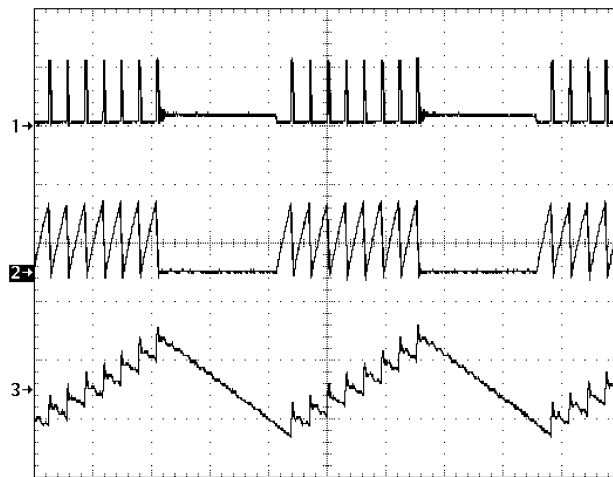

20031518

$V_{OUT} = 20V$, $V_{IN} = 2.5V$
 1) V_{SW} , 20V/div, DC
 2) Inductor Current, 500mA/div, DC
 3) V_{OUT} , 100mV/div, AC
 $T = 10\mu s/div$

FIGURE 3. Typical Switching Waveform

Operation (Continued)

The LM2704 features a constant off-time control scheme. Operation can be best understood by referring to *Figure 2* and *Figure 3*. Transistors Q1 and Q2 and resistors R3 and R4 of *Figure 2* form a bandgap reference used to control the output voltage. When the voltage at the FB pin is less than 1.237V, the Enable Comp in *Figure 2* enables the device and the NMOS switch is turned on pulling the SW pin to ground. When the NMOS switch is on, current begins to flow through inductor L while the load current is supplied by the output capacitor C_{OUT}. Once the current in the inductor reaches the peak current limit, the CL Comp trips and the 400ns One Shot turns off the NMOS switch. The SW voltage will then rise to the output voltage plus a diode drop and the inductor current will begin to decrease as shown in *Figure 3*. During this time the energy stored in the inductor is transferred to C_{OUT} and the load. After the 400ns off-time the NMOS switch is turned on and energy is stored in the inductor again. This energy transfer from the inductor to the output causes a stepping effect in the output ripple as shown in *Figure 3*.

This cycle is continued until the voltage at FB reaches 1.237V. When FB reaches this voltage, the enable comparator then disables the device turning off the NMOS switch and reducing the I_q of the device to 40uA. The load current is then supplied solely by C_{OUT} indicated by the gradually decreasing slope at the output as shown in *Figure 3*. When the FB pin drops slightly below 1.237V, the enable comparator enables the device and begins the cycle described previously. The $\overline{\text{SHDN}}$ pin can be used to turn off the LM2704 and reduce the I_q to 0.01uA. In shutdown mode the output voltage will be a diode drop lower than the input voltage.

Application Information

INDUCTOR SELECTION

The appropriate inductor for a given application is calculated using the following equation:

$$L = \left(\frac{V_{\text{OUT}} - V_{\text{IN}(\text{min})} + V_{\text{D}}}{I_{\text{CL}}} \right) T_{\text{OFF}}$$

where V_D is the schottky diode voltage, I_{CL} is the switch current limit found in the *Typical Performance Characteristics* section, and T_{OFF} is the switch off time. When using this equation be sure to use the minimum input voltage for the application, such as for battery powered applications. For the LM2704 constant-off time control scheme, the NMOS power switch is turned off when the current limit is reached. There is approximately a 200ns delay from the time the current limit is reached in the NMOS power switch and when the internal logic actually turns off the switch. During this 200ns delay, the peak inductor current will increase. This increase in inductor current demands a larger saturation current rating for the inductor. This saturation current can be approximated by the following equation:

$$I_{\text{PK}} = I_{\text{CL}} + \left(\frac{V_{\text{IN}(\text{max})}}{L} \right) 200\text{ns}$$

Choosing inductors with low ESR decrease power losses and increase efficiency.

Care should be taken when choosing an inductor. For applications that require an input voltage that approaches the output voltage, such as when converting a Li-Ion battery voltage to 5V, the 400ns off time may not be enough time to discharge the energy in the inductor and transfer the energy to the output capacitor and load. This can cause a ramping effect in the inductor current waveform and an increased ripple on the output voltage. Using a smaller inductor will cause the I_{PK} to increase and will increase the output voltage ripple further. This can be solved by adding a 4.7pF capacitor across the R_{F1} feedback resistor (*Figure 2*) and slightly increasing the output capacitor. A smaller inductor can then be used to ensure proper discharge in the 400ns off time.

DIODE SELECTION

To maintain high efficiency, the average current rating of the schottky diode should be larger than the peak inductor current, I_{PK}. Schottky diodes with a low forward drop and fast switching speeds are ideal for increasing efficiency in portable applications. Choose a reverse breakdown of the schottky diode larger than the output voltage.

CAPACITOR SELECTION

Choose low ESR capacitors for the output to minimize output voltage ripple. Multilayer ceramic capacitors are the best choice. For most applications, a 1uF ceramic capacitor is sufficient. For some applications a reduction in output voltage ripple can be achieved by increasing the output capacitor.

Local bypassing for the input is needed on the LM2704. Multilayer ceramic capacitors are a good choice for this as well. A 4.7uF capacitor is sufficient for most applications. For additional bypassing, a 100nF ceramic capacitor can be used to shunt high frequency ripple on the input.

LAYOUT CONSIDERATIONS

The input bypass capacitor C_{IN}, as shown in *Figure 1*, must be placed close to the IC. This will reduce copper trace resistance which effects input voltage ripple of the IC. For additional input voltage filtering, a 100nF bypass capacitor can be placed in parallel with C_{IN} to shunt any high frequency noise to ground. The output capacitor, C_{OUT}, should also be placed close to the IC. Any copper trace connections for the Cout capacitor can increase the series resistance, which directly effects output voltage ripple. The feedback network, resistors R1 and R2, should be kept close to the FB pin to minimize copper trace connections that can inject noise into the system. The ground connection for the feedback resistor network should connect directly to an analog ground plane. The analog ground plane should tie directly to the GND pin. If no analog ground plane is available, the ground connection for the feedback network should tie directly to the GND pin. Trace connections made to the inductor and schottky diode should be minimized to reduce power dissipation and increase overall efficiency.

Application Information (Continued)

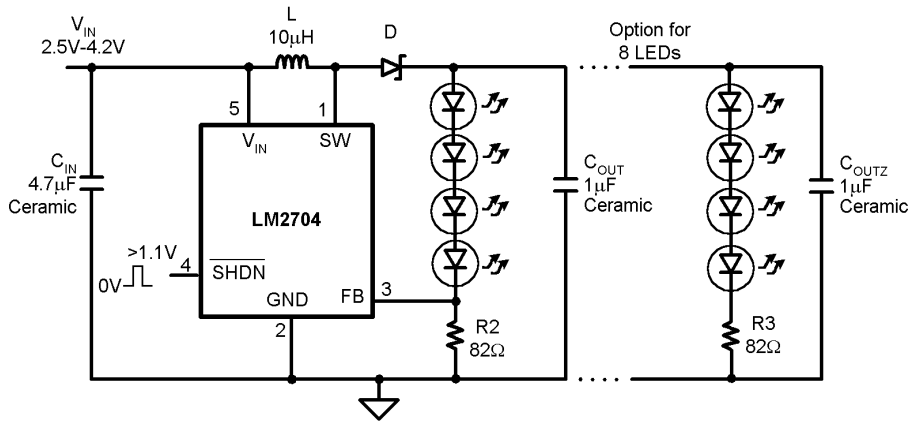

C_{IN}: Taiyo Yuden Ceramic
 C_{OUT}: Taiyo Yuden Ceramic
 L: Coilcraft DO1608C-103
 D: Motorola MBRM130LT3

20031509

FIGURE 4. White LED Application

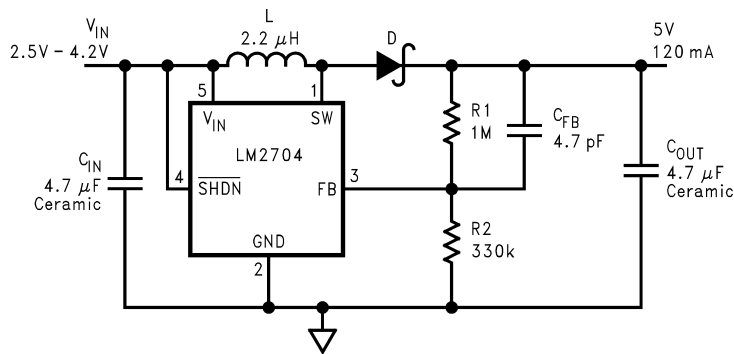

20031534

FIGURE 5. Li-Ion 5V Application

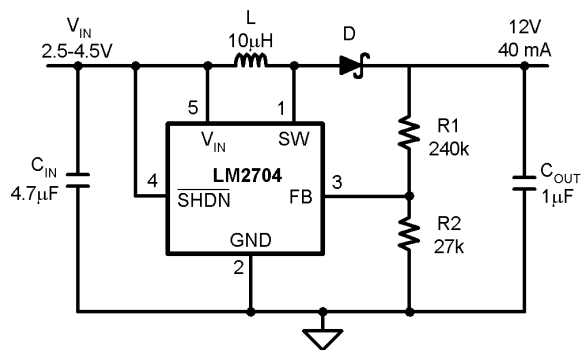

20031535

FIGURE 6. Li-Ion 12V Application

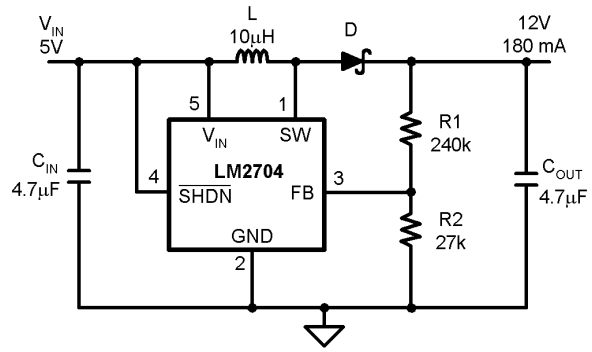
Application Information (Continued)

20031536

FIGURE 7. 5V to 12V Application

Physical Dimensions inches (millimeters) unless otherwise noted

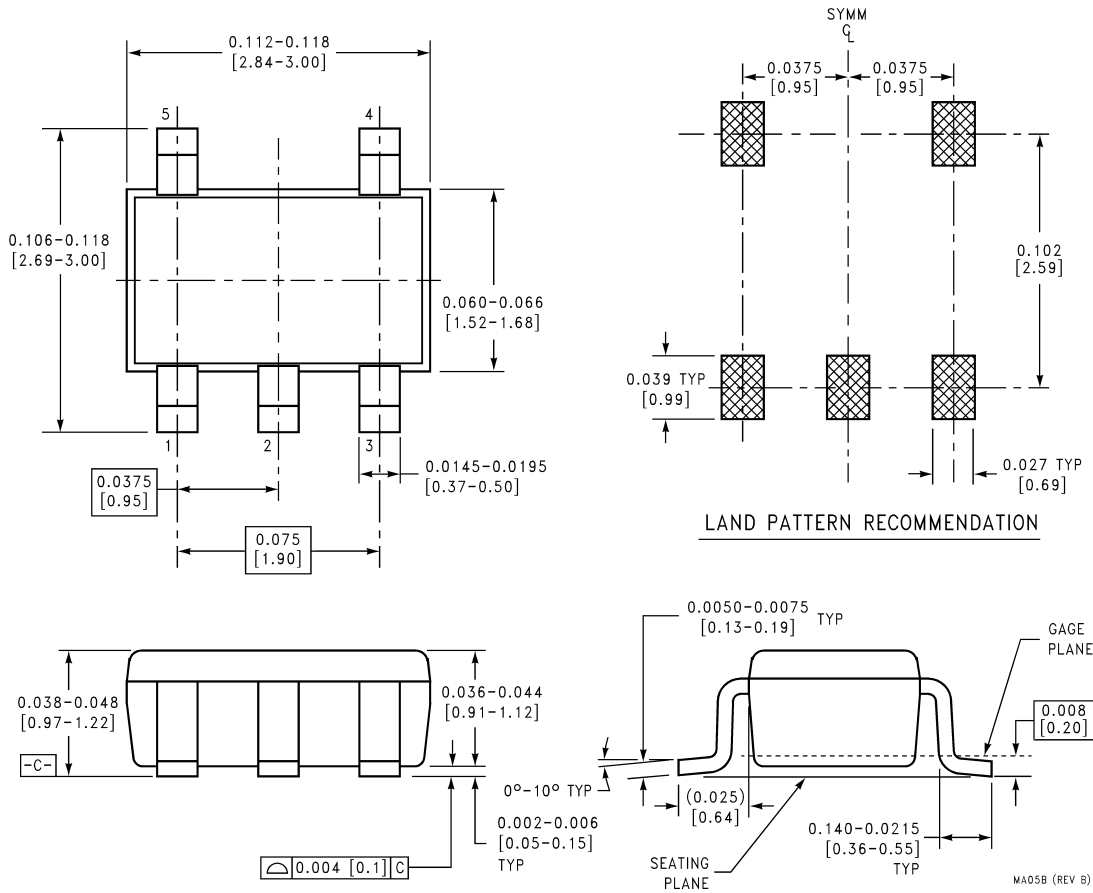

5-Lead Small Outline Package (M5)
For Ordering, Refer to Ordering Information Table
NS Package Number MA05B

LIFE SUPPORT POLICY

NATIONAL'S PRODUCTS ARE NOT AUTHORIZED FOR USE AS CRITICAL COMPONENTS IN LIFE SUPPORT DEVICES OR SYSTEMS WITHOUT THE EXPRESS WRITTEN APPROVAL OF THE PRESIDENT AND GENERAL COUNSEL OF NATIONAL SEMICONDUCTOR CORPORATION. As used herein:

1. Life support devices or systems are devices or systems which, (a) are intended for surgical implant into the body, or (b) support or sustain life, and whose failure to perform when properly used in accordance with instructions for use provided in the labeling, can be reasonably expected to result in a significant injury to the user.
2. A critical component is any component of a life support device or system whose failure to perform can be reasonably expected to cause the failure of the life support device or system, or to affect its safety or effectiveness.



National Semiconductor
Americas Customer
Support Center
 Email: new.feedback@nsc.com
 Tel: 1-800-272-9959

www.national.com

National Semiconductor
Europe Customer Support Center
 Fax: +49 (0) 180-530 85 86
 Email: europe.support@nsc.com
 Deutsch Tel: +49 (0) 69 9508 6208
 English Tel: +44 (0) 870 24 0 2171
 Français Tel: +33 (0) 1 41 91 8790

National Semiconductor
Asia Pacific Customer
Support Center
 Fax: +65-6250 4466
 Email: ap.support@nsc.com
 Tel: +65-6254 4466

National Semiconductor
Japan Customer Support Center
 Fax: 81-3-5639-7507
 Email: jpn.feedback@nsc.com
 Tel: 81-3-5639-7560